

Hand Pallet Truck



Model: BF

1KG=2.205LB 1INCH=25.40MM

Model	BF	
Capacity	Q(kg)	2500/3000
Lowered fork height	h_2 (mm)	85
Steering wheel	mm	ϕ 200
Fork wheel single	mm	ϕ 80x93
Fork wheel tandem	mm	ϕ 80x70
Max. lift height	h_1 (mm)	200
Total height	h_3 (mm)	1224
Overall length	l_1 (mm)	1483/1533/1603
Fork length	l (mm)	1100/1150/1220
Width overall forks	b_1 (mm)	520/550/685
Ground clearance, centre of wheelbase	m_1 (mm)	40
Aisle width for pallets 1000x1200 crossways	A_1 (mm)	1683/1733/1803
Aisle width for pallets 800x1200 lengthways	A_2 (mm)	1783/1783/1803
Turning radius	W_1 (mm)	1216/1266/1336
Service weight	kg	60-75

Over
5,000,000
units sold



Innovative design, comprehensive testing and highest quality !

- Most standard and popular model with capacity 2500 - 3000kgs.
- With Copping Supporting NOG & strengthening ribbing under top triangle cover.
- Complete pump design with reliable leak-proof pump eliminating maintenance and extending the service time.
- 210 steering arc, and small turning radius.
- Fork Lowering speed is controllable, operated by hand control and foot pedal.
- Entry / exit roller, more freely travel.
- Equipped with over-load valve, with long service time.
- 3 position hand control - Raise, Lower, Neutral.
- 12 lubrication grease nipples on all movable parts for easy maintenance.
- Adjustable pump cap ensures a long service life.
- Ergonomic large rubber handle with three control lever.
- Option: 1) Nylon wheel, polyurethane wheel, rubber wheel, single fork roller or tandem fork rollers.
2) Fork length: 800mm, 900mm, 1000mm.
3) Foot pedal release.
4) Pump color: black painting, silver painting.



Conforms to EN ISO3691-5
Based on Directive 2006/42/EC

Professional



Option: fully rubber wrapped handle



Adjustable pump cap

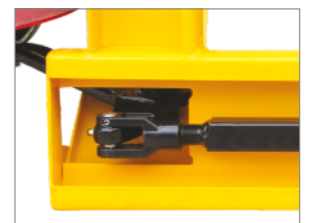

Adjustable straight tappet

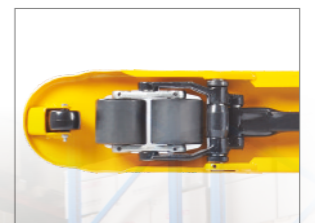

Additional entry and exit roller

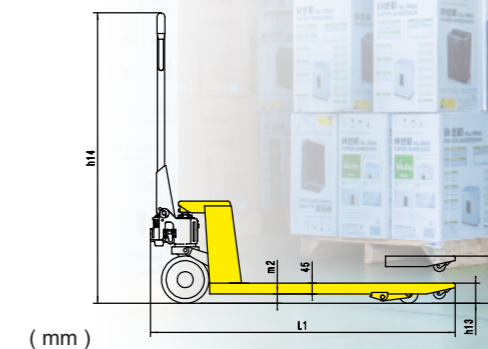
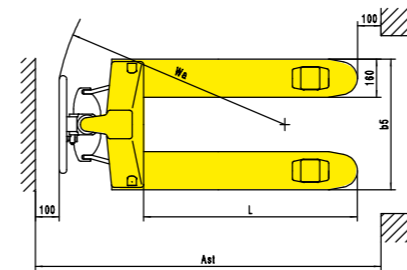

Remark: Special size fork width and length can be made according to customer's requirement.

Electric Pallet Truck

Electric Stackcar

Order Picker

Narrow Aisle Truck

Electric Tow Tractor

Hand Pallet Truck

Manual Stackcar

Lift Table