

Model: BF-III

1KG=2.205LB 1INCH=25.40MM

Model	BF-III	
Capacity	Q(kg)	2500/3000 2500/3000
Lowered fork height	h_2 (mm)	85 75
Steering wheel	mm	ϕ 180 ϕ 180
Fork wheel single	mm	ϕ 74x93 ϕ 74x93
Fork wheel double	mm	ϕ 74x70 ϕ 74x70
Max. Lifting height	h_1 (mm)	195 185
Height of tiller in drive position min./max.	h_{11} (mm)	1214 1214
Overall length	l_1 (mm)	1543/1613 1543/1613
Fork length	l (mm)	1150/1220 1150/1220
Width overall forks	b_1 (mm)	520/550/685 520/550/685
Ground clearance, center of wheelbase	m_1 (mm)	32 22
Aisle width for pallets 1000x1200 crossways	A_1 (mm)	1743/1813 1743/1813
Aisle width for pallets 800x1200 lengthways	A_2 (mm)	1793/1813 1793/1813
Turning radius	W_1 (mm)	1276/1346 1276/1346
Service weight	kg	56-70 56-70

Remark: Special size fork width and length can be made according to customer's requirement.

Hot Sale



Hand pallet truck

- Integrated pump without welding , no any leaking problems.
- Frame force is more reasonable , and the strength is more reliable.
- Handle seat has hole it is more convenient for installation of control chain.
- Forks lowering speed is controllable, with overload valve to avoid overloading .
- Option: 1) steering wheel 200mm (fork wheel 80mm) are available.
2) Nylon wheel, polyurethane wheel, rubber wheel, single fork roller or tandem fork rollers.
3) Fork length: 800mm, 900mm, 1000mm, 1100mm.
4) Foot pedal release.
5) Pump color: black painting.
6) Quick lift (double speed lifting).



Conforms to EN ISO3691-5
Based on Directive 2006/42/EC

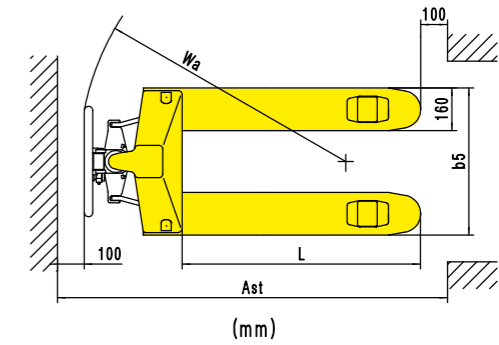
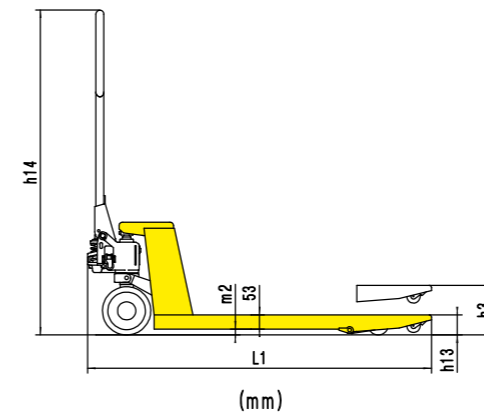

Wheel Option

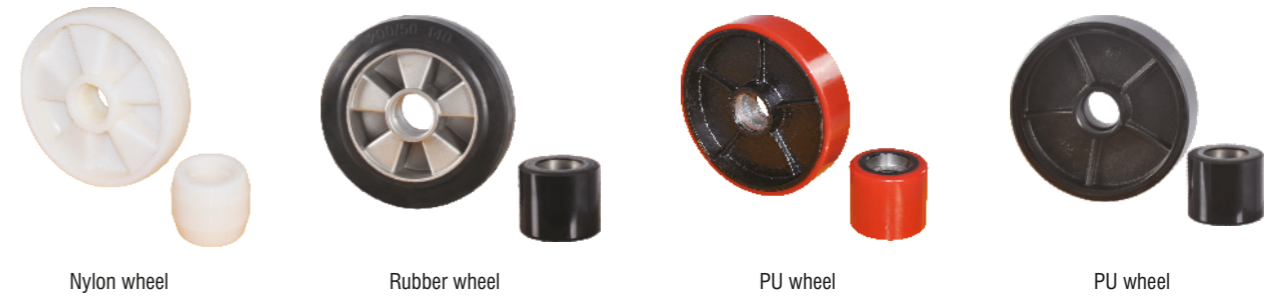

Handle Option



*Standard: metal handle



*Option: rubber wrapped handle

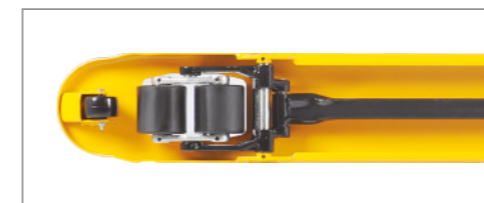

Standard with entry & exist Roller
(option with single or double fork rollers)



Integrated cast pump