

Double Decker Pallet Truck



Model:
CBD20S
AC

CE
Conforms to EN ISO3691-1
EN1175-1
EN16307-1
Based on Directive 2006/42/EC



Side-way Battery



Vertical System

1KG=2.205LB 1INCH=25.40MM

Model		CBD20S	CBD20S-III
Load capacity/rated load	Q(kg)	2000	2000
Load capacity/rated load with mast lift	Q(kg)	1000	1000
Load capacity/rated load with wheel arm lift	Q(kg)	2000	2000
Load center distance	c(mm)	600	600
Load distance, center of drive axle to fork	x(mm)	831	802
Fork height, lowered	h ₃ (mm)	90	90
Tyre size, front	mm	φ 250x70	φ 250x70
Tyre size, rear	mm	φ 80x70	φ 80x70
Additional wheels(dimensions)	mm	φ 127x57	φ 114x60
Wheels, number front rear(x=driven wheels)		1X+2/4	1X+2/4
Height, mast lowered	h ₁ (mm)	1082/1212/1382	-
Max. lift height	h ₂ (mm)	1600/2000/2500	800
Initial lift	h ₂ (mm)	120	120
Height of tiller in drive position min./max.	h ₁ (mm)	780/1230	780/1230
Overall length	l ₁ (mm)	1962	1760
Length to face of forks	l ₂ (mm)	862	608
Overall width	b ₁ (mm)	775	682
Fork dimensions	s/e/l(mm)	60/180/1100	60/180/1150
Width overall forks	b ₂ (mm)	570/650	550
Aisle width for pallets 1000x1200 crossways	A ₁ (mm)	2238	1972
Aisle width for pallets 800x1200 lengthways	A ₂ (mm)	2288	2022
Turning radius	W ₁ (mm)	1705	1422
Travel speed,laden/unladen	Km/h	4.5/5.2	6/6
Lift speed,laden/unladen	m/s	0.03/0.04	0.06/0.11
Lowering speed,laden/unladen	m/s	0.05/0.045	0.12/0.13
Battery voltage,nominal capacity K ₂	V/Ah	24/210	24/160
Battery weight	Kg	196	160
Battery dimensions l/w/h	mm	750x170x580	645x148x560
Service weight(with battery)	Kg	950	600

* Option: CBD20S Lithium battery 125AH (Charger 24V/50A)
CBD20S-III Lithium battery 100AH (Charger 24V/50A)

Advantages:

SAFETY AND EFFICIENCY

- Carry two pallets at one single time.
- The tiller head is equipped with an emergency reverse direction switch, which provides safer operation.
- Built-in pressure relief valve protects the truck from overload, and increases the truck's safety.
- Stepless speed control and turtle speed switch.

STRUCTURAL

- Vertical driving wheel offers small turning radius.
- Dividable and exchangeable mast.
- Adjustable floating balance wheel is resistant to wear and stable.
- Sliding rail connects the moving part of the front and rear, makes lifting and lowering stable.

EASY MAINTENANCE

- Hall-effect throttle control eliminates wear components and prolongs its use time.
- The balance wheel is detachable, convenient to maintain.
- Integral and modularized electrical system makes the maintenance of the electrical parts convenient.

Model:
CBD20S-III



Standard mast types

Three-stage mast			
h1	h2	h3	h4
1082	~	1600	2118
1212	~	2000	2508
1382	~	2500	3018

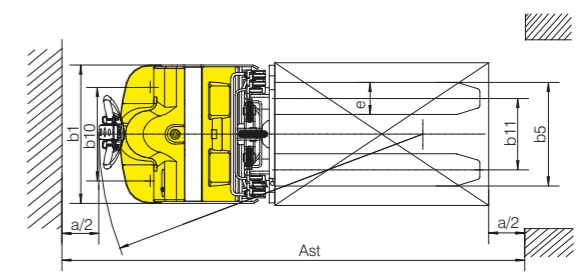
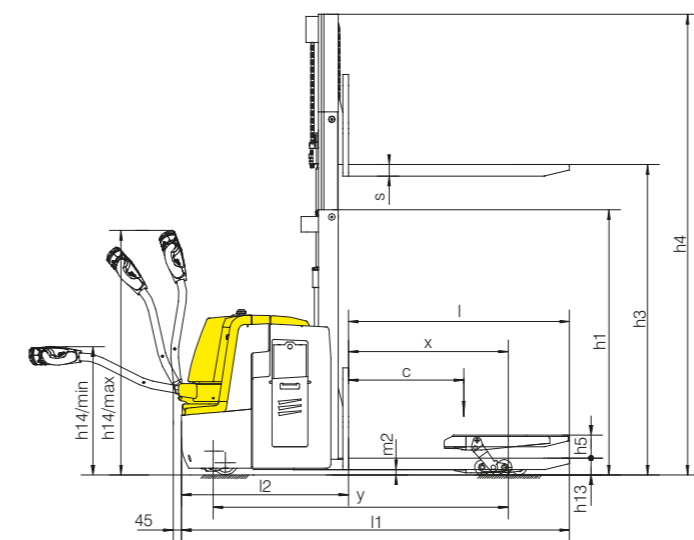

Electric Pallet Truck
Electric Stackers
Order Picker
Narrow Aisle Truck
Electric Tow Tractor
Hand Pallet Truck
Manual Stacker
Lift Table

1KG=2.205LB 1INCH=25.40MM

Model		CBD20Z	CBD25Z
Operate type		seated	seated
Load capacity	Q(kg)	2000	2500
Load centre distance	c(mm)	600	600
Load distance, centre of drive axle to fork	x(mm)	914/964/1034	914/964/1034
Height, lowered	h ₁ (mm)	82	82
Tyre size, front	mm	φ 250x80	φ250×80
Tyre size, rear	mm	φ 82x98	φ82×98
Additional wheels(dimensions)	mm	φ 160x55	φ160×55
Wheels, number front rear(x=driven wheels)		1X+1/4	1X+1/4
Max. lift height	h ₂ (mm)	202	202
Seat height/stand height	h ₃ (mm)	900	900
Overall length	l ₁ (mm)	1900/1950/2020	1900/1950/2020
Length to face of forks	l ₂ (mm)	800	800
Overall width	b ₁ (mm)	864	864
Fork dimensions	s/e/l(mm)	54x180x1100(1150/1220)	54×180×1100(1150/1220)
Width overall forks	b ₂ (mm)	520/550/650/685	520/550/650/685
Aisle width for pallets 1000x1200 crossways	A ₁₁ (mm)	2465/2505/2565	2465/2505/2565
Aisle width for pallets 800x1200 lengthways	A ₁₂ (mm)	2385/2400/2430	2385/2400/2430
Turning radius	W ₁ (mm)	1630/1680/1750	1630/1680/1750
Travel speed, laden/unladen	Km/h	7.5/8	7.5/8
Battery voltage, nominal capacity K ₂	V/Ah	24/270	24/300
Battery weight	Kg	264	270
Service weight(with battery)	Kg	900	900

* Option: CBD25Z Lithium battery 225AH (Charger 24V/100A)

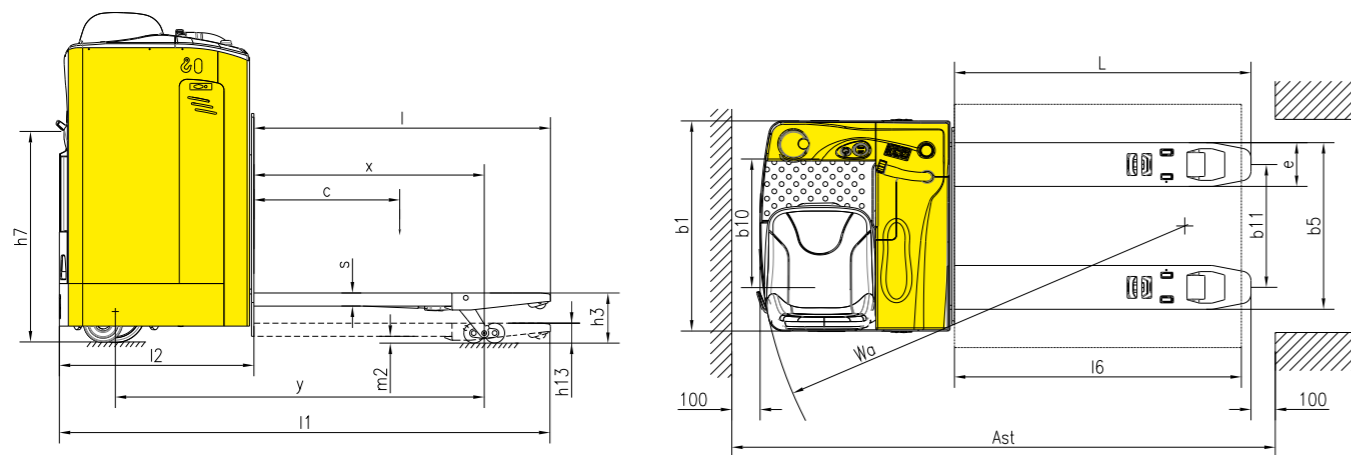

Model: CBD20S

The CBD20S, with small turning radius and lowest height (1.08~1.38m), offers Double pallet Initial lifting, with Initial lift have 120mm lift to easily negotiate over ramps and bridging plates as well as the ability to transport a 2000kg load, widely used in low shelves warehouse and small supermarket etc.

AC

