

Double Decker Pallet Truck

AC

EPS



Model: CBD20SR

The CBD20SR type Electric pallet Stacker with initial lifting, the leg can lift up to 120mm to easily negotiate over ramps and bridging plates, with small turning radius and lowest height (1.08-1.38m), can carry two pallets at same time, widely used in low shelves warehouse and small supermarket .



Conforms to EN ISO3691-1
EN1175-1
EN16307-1
Based on Directive 2006/42/EC
Conform to EN Standard 12895
Based on directive: 2014/30/EU (EMC)

Advantages:

SAFETY AND PRODUCTIVITY:

- Advanced AC control system eliminates the motor brushes and directional contactors, which makes the minimal maintenance requirements. Intelligent regenerative brake system.
- With guard on both sides, protect operator when drive at high speed of the trucks.
- Emergency reversing device.
- Built-in pressure relief valve protects the trucks from overloads.
- Emergency power disconnect.
- With Speed sensor under platform can switch drive speed to Low/high speed when platform is closed/opened.
- Multi function display with BDI(battery discharge indicator) and working hours.
- Multi function display, includes battery status, working hours.
- The bevel design of the bottom provides good traffic ability characteristic. The truck could pass max. 22% slope without laden. And the max gradeability can achieve 8% when laden.
- With Electric Power Steering system (EPS) , makes truck steering very smoothly and light.

STRUCTURAL:

- Hard steel rear cover, anti-collision, easy disassembly, provides the maintenance for the electrical system very convenient.
- Only 90mm lowered fork height, the truck is with good applicability.
- With vertical driving wheel offers small turning radius.
- With floating design for drive axle provides good anti-vibration.
- Side-way battery with roll-out system is very convenient to replace batteries. Achieves the continuity of working.
- When the truck jolts, the connecting rod will never be crooked because of the pull function.

SERVICEABILITY:

- Low battery protection setting prolongs the battery life.
- With Integration electric layout, it is very easy to maintenance. Reliable and shockproof electric system.
- Easy replacement and maintenance for the steering wheel.

1KG=2.205LB 1INCH=25.40MM

Model	CBD20SR	
Operate type	Q(kg)	standing
Load capacity	Q(kg)	2000
Load capacity for mast lift	Q(kg)	1000
Load capacity for rocker lift	c(mm)	2000
Load centre distance	x(mm)	600
Load distance,centre of drive axle to fork	Y(mm)	767
Tyre size,front	Φ250×80	
Tyre size,rear	Φ80×70	
Additional wheels(dimension)	Φ127×57	
Wheels,number front rear(x=driven wheels)	1X+2/4	
Max lifting height	h₃(mm)	1600/2000/2500
Mast height, lowered	h₁(mm)	1082/1212/1382
Mast height , extended	h₄(mm)	2118/2508/3018
Lifting height for leg	h ₅ (mm)	120
Height of tiller in drive position min./max.	h ₁₄ (mm)	1150/1430
Lowered fork height	h ₁₃ (mm)	90
Overall length	l ₁ (mm)	1898/1948
Length to face of forks	l ₂ (mm)	798
Overall width	b ₁ (mm)	775
Fork dimension	s/e/l(mm)	54×180×1100(1150)
Width overall forks	b ₄ (mm)	570/650
Aisle width for pallets 1000x1200 crossways	A ₄₁ (mm)	2098/2148
Aisle width for pallets 800x1200 lengthways	A ₄₂ (mm)	2198
Turning radius	W ₄ (mm)	1600
Travel speed,laden/unladen	Km/h	9/9.1
Lift speed,laden/unladen	m/s	0.11/0.15
Lowering speed, laden/unladen	m/s	0.18/0.18
Service brake	electromagnetic braking	
Battery voltage, nominal capacity k5	V/Ah	24/240
Battery weight	Kg	235
Battery dimension l/w/h	mm	750×170×570
Service weight(with battery)	Kg	1130

* Option: CBD20SR Lithium battery 125AH (Charger 24V/50A)

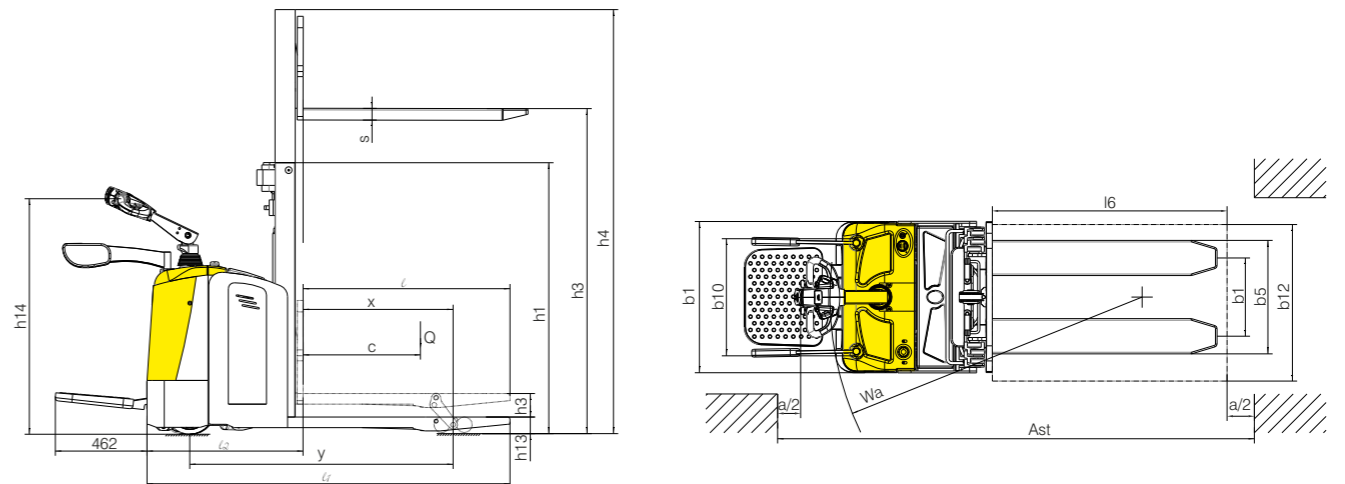

Best solution for operation on uneven ground.

Electric Pallet Truck

Electric Stacker

Order Picker

Narrow Aisle Truck

Electric Tow Tractor

Hand Pallet Truck

Manual Stacker

Lift Table