

Model: DB

1KG=2.205LB 1INCH=25.40MM

Model		DB
Capacity	Q(kg)	2000
Lowered fork height	h_{13} (mm)	75
Steering wheel	mm	ϕ 160
Fork wheel single	mm	ϕ 70x80
Fork wheel tandem	mm	ϕ 70x60
Max. lift height	h_2 (mm)	190
Total height	h_{14} (mm)	1176.5
Overall length	l_1 (mm)	1520/1590
Fork length	l (mm)	1150/1220
Width overall forks	b_5 (mm)	520/550/680
Ground clearance, centre of wheelbase	m_2 (mm)	22
Aisle width for pallets 1000x1200 crossways	A_w (mm)	1720/1790
Aisle width for pallets 800x1200 lengthways	A_s (mm)	1770/1790
Turning radius	W_t (mm)	1265/1335
Service weight	kg	53-62

Remark: Special size fork width and length can be made according to customer's requirement.



Standard



Conforms to EN ISO3691-5
Based on Directive 2006/42/EC

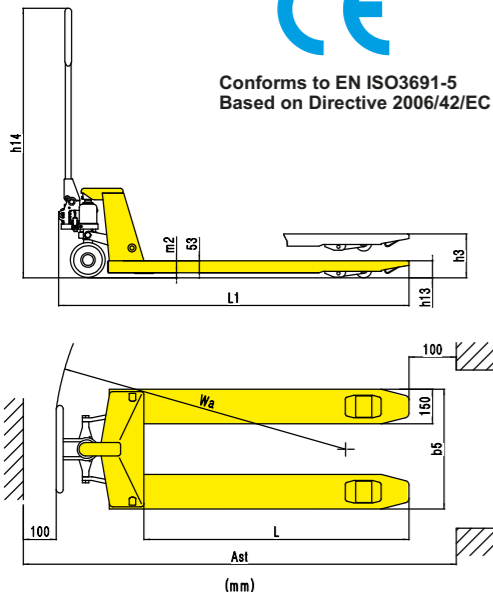

Economic design pallet truck

- Standard epoxy powder coat finish which is resistant to chips and normal corrosion.
- Exceptionally strong but light weight steel construction, service weight is only 55kgs.
- With welded joints and reinforced fork tips for most durability in the toughest applications.
- 3 position hand control - Raise, Lower, Neutral.
- Excellent turning angle of 190 degrees facilities.
- Number of pump strokes 12 times, lift height per stroke 11mm.
- Reliable oil leak-proof hydraulic system.
- Option: 1) Nylon wheel, polyurethane wheel, rubber wheel, single fork roller or tandem fork rollers.
2) Fork length: 800mm, 900mm, 1000mm, 1100mm.

Model: DF-III

1KG=2.205LB 1INCH=25.40MM

Model		DF-III	
Capacity	Q(kg)	2500/3000	2500/3000
Lowered fork height	h_{13} (mm)	85	75
Steering wheel	mm	ϕ 180	ϕ 160
Fork wheel single	mm	ϕ 70x80	ϕ 70x80
Fork wheel tandem	mm	ϕ 70x60	ϕ 70x60
Max. lift height	h_2 (mm)	200	190
Total height	h_{14} (mm)	1186.5	1176.5
Overall length	l_1 (mm)	1520/1590	1520/1590
Fork length	l (mm)	1150/1220	1150/1220
Fork width	e (mm)	150	150
Width overall forks	b_5 (mm)	520/550/680	520/550/680
Ground clearance, centre of wheelbase	m_2 (mm)	32	22
Aisle width for pallets 1000x1200 crossways	A_w (mm)	1720/1790	1720/1790
Aisle width for pallets 800x1200 lengthways	A_s (mm)	1770/1790	1770/1790
Turning radius	W_t (mm)	1265/1335	1265/1335
Service weight	kg	55-65	55-65

Remark: (1) Capacity 2000kg available.

(2) Special size fork width and length can be made according to customer's requirement.



*Standard
(Innovation)*



Conforms to EN ISO3691-5
Based on Directive 2006/42/EC

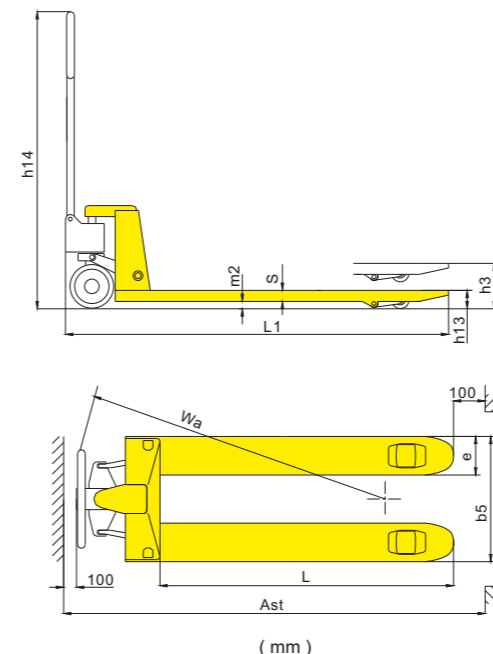

Standard type pallet truck

- Chrome piston and ram for smooth operation and prevents excessive wear on the pump & seal.
- Excellent turning angle of 180 degrees facilities.
- Number of pump strokes-10 times. Lift height per stroke:11mm.
- Option: 1) Nylon wheel, polyurethane wheel, rubber wheel, single fork roller or tandem fork rollers.
2) Fork length: 800mm, 900mm, 1000mm.